

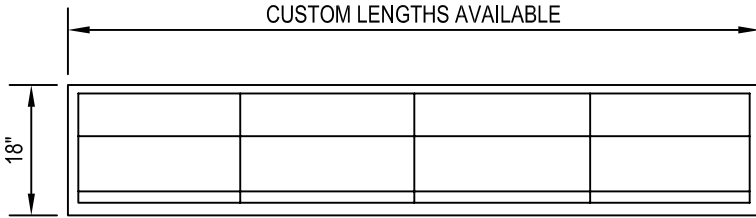

THE CHANDLER COMPANY
 2621 SOUTH BIRCH STREET
 SANTA ANA, CA, USA, 92707
 PHONE: (714) 979-4212
 FAX: (714) 979-4854
 www.thechandlercompany.com

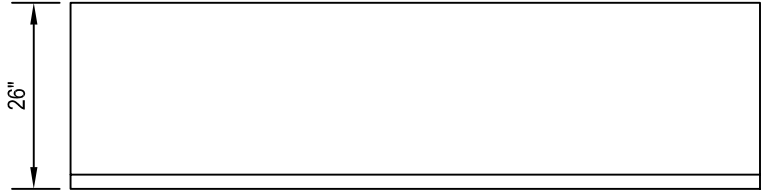

TOP VIEW



BOTTOM VIEW

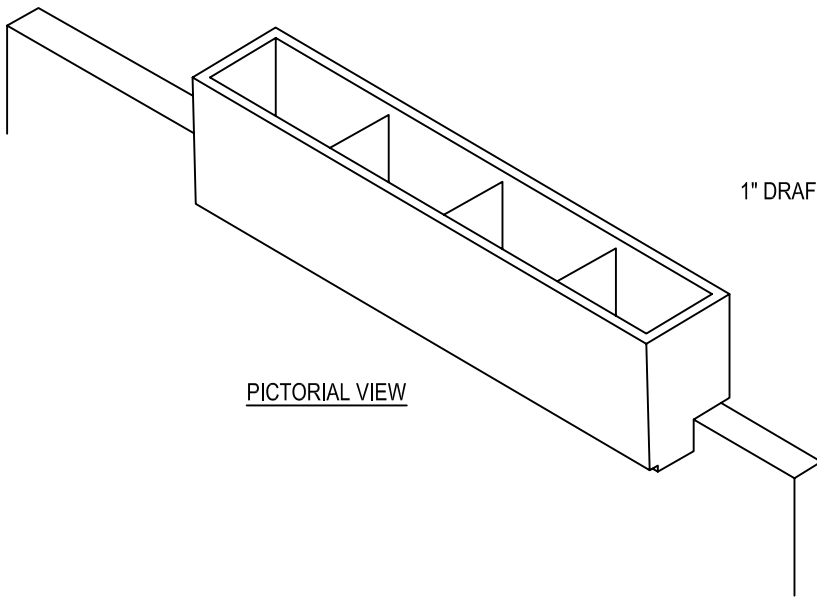

PICTORIAL VIEW

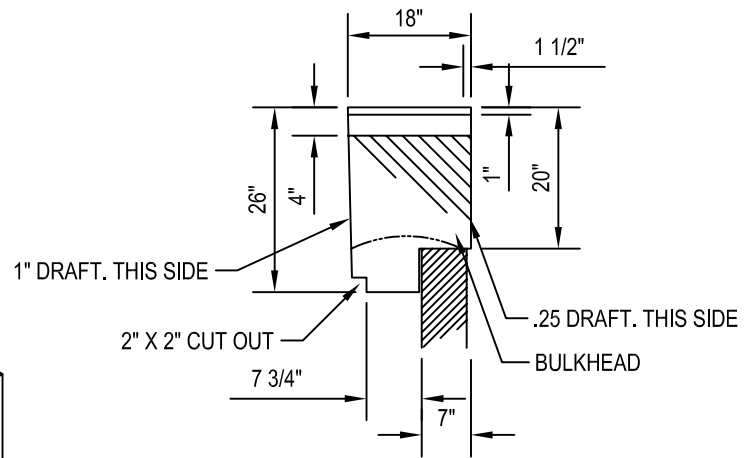

CROSS SECTION

NOTES:

1. INSTALLATION TO BE COMPLETED IN ACCORDANCE WITH MANUFACTURER'S SPECIFICATIONS.
2. DO NOT SCALE DRAWINGS.
3. BULKHEADS 18"W X 16"H @ 24" INTERVALS ARE GLASSED TO FRONT AND BACK OF PLANTER. THESE MAY TELEGRAPH SLIGHTLY THROUGH THE FACE OF THE PLANTER.
4. PLANTER SITS ON PRE-CAST OR CMU WALL AND IS SECURED W/ FENDER WASHERS, AND THE APPROPRIATE FASTENERS.
5. CONTACT MANUFACTURER FOR CUSTOM SIZES.
6. CONTRACTORS NOTE: FOR PRODUCT AND COMPANY INFORMATION VISIT www.CADdetails.com/info REFERENCE NUMBER 600-023.

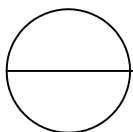

PARKING STRUCTURE PLANTER 1